

# AC axial fan

sickle-shaped blades (S series)  
with guard grille for short nozzle

## ebm-papst Mulfingen GmbH & Co. KG

Bachmühle 2 · D-74673 Mulfingen

Phone +49 7938 81-0

Fax +49 7938 81-110

info1@de.ebmpapst.com

www.ebmpapst.com

Limited partnership · Headquarters Mulfingen

Amtsgericht (court of registration) Stuttgart · HRA 590344

General partner Elektrobau Mulfingen GmbH · Headquarters Mulfingen

Amtsgericht (court of registration) Stuttgart · HRB 590142



## Nominal data

Type	S6D630-AE01-01				
Motor	M6D110-GF				
Phase		1~	3~	3~	3~
Nominal voltage	VAC	400	400	480	480
Wiring		Δ	Y	Δ	Y
Frequency	Hz	50	50	60	60
Method of obtaining data		ml	ml	ml	ml
Valid for approval/standard		CE	CE	CE	CE
Speed (rpm)	min <sup>-1</sup>	890	680	1070	830
Power consumption	W	610	410	830	550
Current draw	A	1.26	0.75	1.37	0.83
Max. back pressure	Pa	105	60	55	35
Max. back pressure	inH <sub>2</sub> O	0.42	0.24	0.22	0.14
Min. ambient temperature	°C	-40	-40	-40	-40
Max. ambient temperature	°C	75	75	65	65
Starting current	A	4	4		

ml = Max. load · me = Max. efficiency · fa = Free air · cs = Customer specification · ce = Customer equipment  
Subject to change

## Data according to ErP Directive

	Actual	Req. 2015				
01 Overall efficiency $\eta_{es}$	%	34.5	32.1	09 Power consumption $P_e$	kW	0.56
02 Measurement category		A		09 Air flow $q_v$	m <sup>3</sup> /h	7215
03 Efficiency category		Static		09 Pressure increase $p_{fs}$	Pa	97
04 Efficiency grade N		42.4	40	10 Speed (rpm) n	min <sup>-1</sup>	905
05 Variable speed drive		No		11 Specific ratio*		1.00

Data obtained at optimum efficiency level.

The ErP data is determined using a motor-impeller combination in a standardized measurement setup.

\* Specific ratio =  $1 + p_{fs} / 100\,000\text{ Pa}$

LU-70230



# AC axial fan

sickle-shaped blades (S series)  
with guard grille for short nozzle

## Technical description

Weight	15.6 kg
Fan size	630 mm
Rotor surface	Cast in aluminum
Terminal box material	PP plastic
Blade material	Sheet aluminum
Guard grille material	Steel, coated with black plastic (RAL 9005)
Number of blades	5
Blade pitch	-5°
Airflow direction	"V"
Direction of rotation	Counterclockwise, viewed toward rotor
Degree of protection	IP54
Insulation class	"F"
Moisture (F) / Environmental (H) protection class	F3-1
Max. permitted ambient temp. for motor (transport/storage)	+80 °C
Min. permitted ambient temp. for motor (transport/storage)	-40 °C
Installation position	Shaft horizontal or rotor on bottom; rotor on top on request
Condensation drainage holes	On rotor side
Mode	S1
Motor bearing	Ball bearing
Touch current according to IEC 60990 (measuring circuit Fig. 4, TN system)	<= 3.5 mA
Electrical hookup	Via terminal box
Motor protection	Thermal overload protector (TOP) with basic insulation
With cable	Axial
Protection class	I (with customer connection of protective earth)
Conformity with standards	EN 61800-5-1; CE
Approval	VDE; EAC



# AC axial fan

sickle-shaped blades (S series)  
with guard grille for short nozzle

## Product drawing

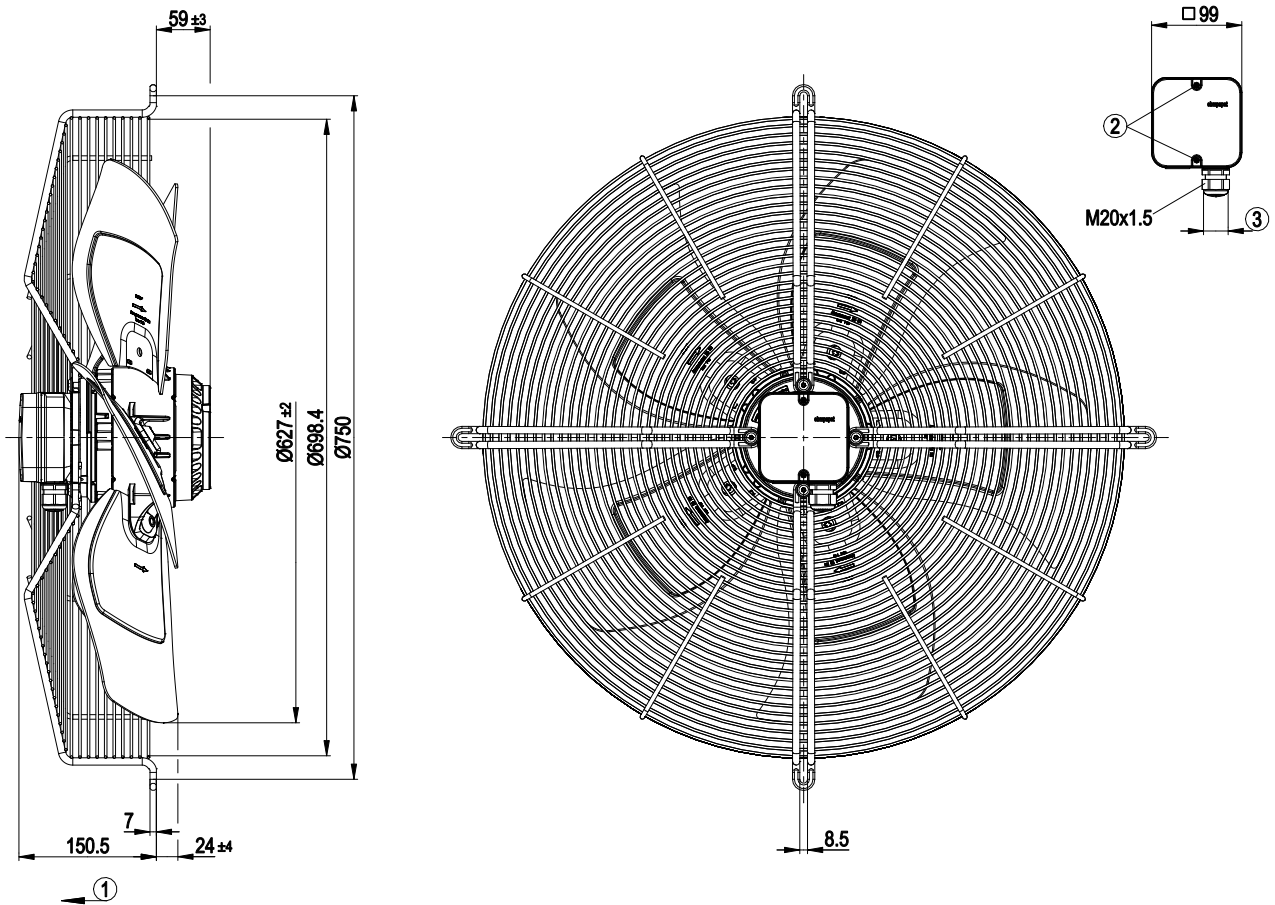

1	Direction of air flow "V"
2	Tightening torque 1.5 ± 0.2 Nm
3	Cable diameter: min. 6 mm, max. 12 mm, tightening torque 2±0.3 Nm



# AC axial fan

sickle-shaped blades (S series)  
with guard grille for short nozzle

## Connection diagram

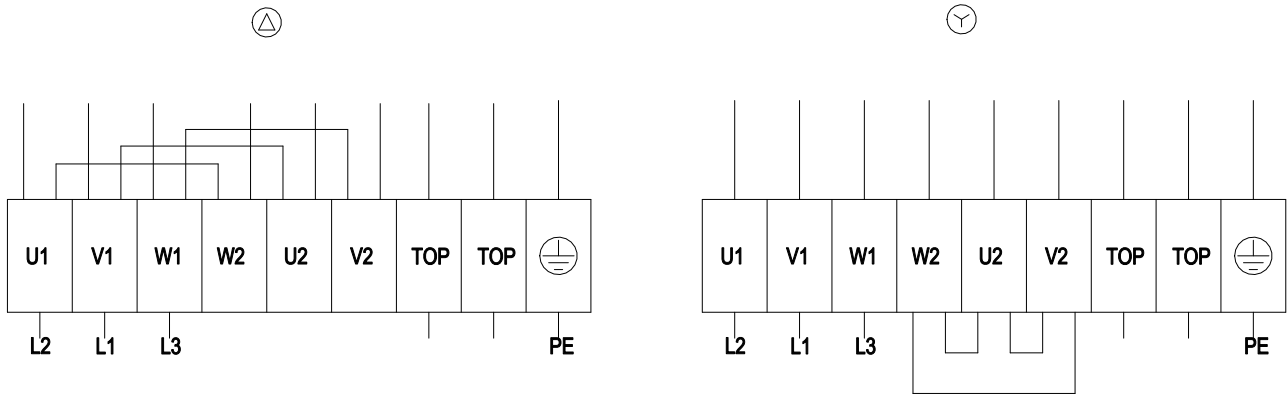

Δ	Delta connection	Y	Star connection	L1	= V1 = blue
L2	= U1 = black	L3	= W1 = brown	W2	yellow
U2	green	V2	white	TOP	2x gray
PE	green/yellow				

# AC axial fan

sickle-shaped blades (S series)  
with guard grille for short nozzle

## Curves: Air performance 50 Hz

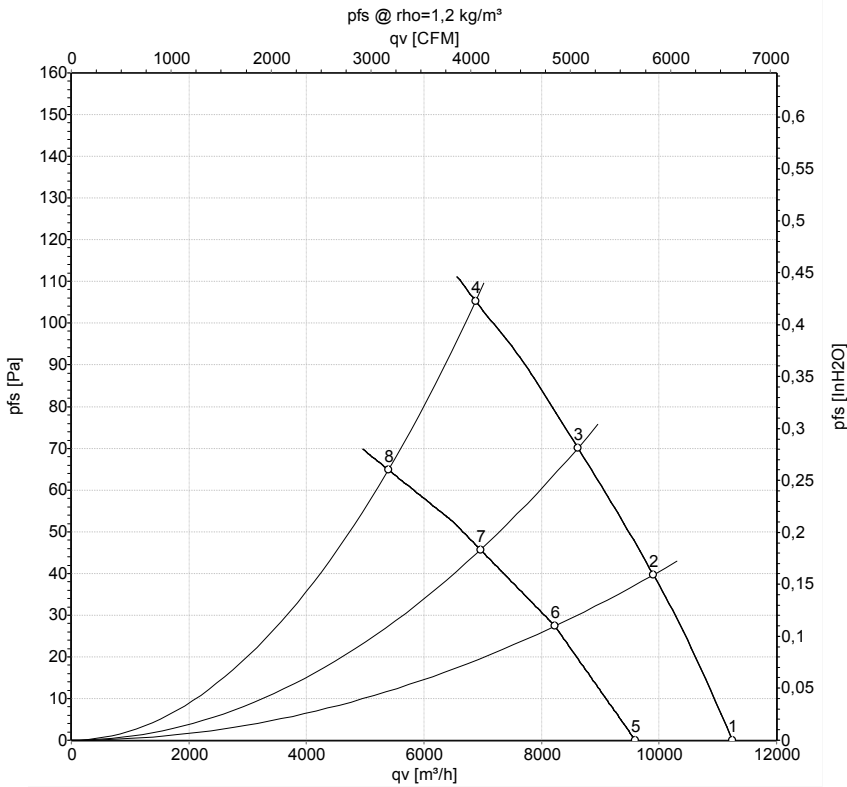

Measurement: LU-106028-1  
Measurement: LU-125496-1

Air performance measured according to ISO 5801 installation category A. For detailed information on the measurement setup, contact ebm-papst. Intake sound level: Sound power level according to ISO 13347 / sound pressure level measured at 1 m distance from fan axis. The values given are valid under the specified measuring conditions and may vary due to conditions of installation. For deviations from the standard configuration, the parameters have to be checked on the installed unit.

## Measured values

	Wired	U	f	n	P <sub>e</sub>	I	LpA <sub>in</sub>	LwA <sub>in</sub>	LwA <sub>out</sub>	qv	p <sub>fs</sub>	qv	p <sub>fs</sub>
		V	Hz	min <sup>-1</sup>	W	A	dB(A)	dB(A)	dB(A)	m <sup>3</sup> /h	Pa	CFM	inH2O
1	Δ	400	50	930	439	1.10	70	77	77	11250	0	6620	0.00
2	Δ	400	50	915	500	1.14	69	75	76	9905	40	5830	0.16
3	Δ	400	50	905	551	1.20	69	75	76	8620	70	5075	0.28
4	Δ	400	50	890	610	1.26	70	76	77	6875	105	4045	0.42
5	Y	400	50	795	324	0.59	67	73	73	9595	0	5650	0.00
6	Y	400	50	750	356	0.63	64	71	71	8225	27	4840	0.11
7	Y	400	50	725	378	0.67	64	70	71	6960	46	4095	0.18
8	Y	400	50	680	410	0.75	64	70	71	5395	65	3175	0.26

Wired = Wiring · U = Power supply · f = Frequency · n = Speed (rpm) · P<sub>e</sub> = Power consumption · I = Current draw · LpA<sub>in</sub> = Sound pressure level intake side · LwA<sub>in</sub> = Sound power level intake side  
LwA<sub>out</sub> = Sound power level outlet side · qv = Air flow · p<sub>fs</sub> = Pressure increase



# AC axial fan

sickle-shaped blades (S series)  
with guard grille for short nozzle

## Curves: Air performance 60 Hz

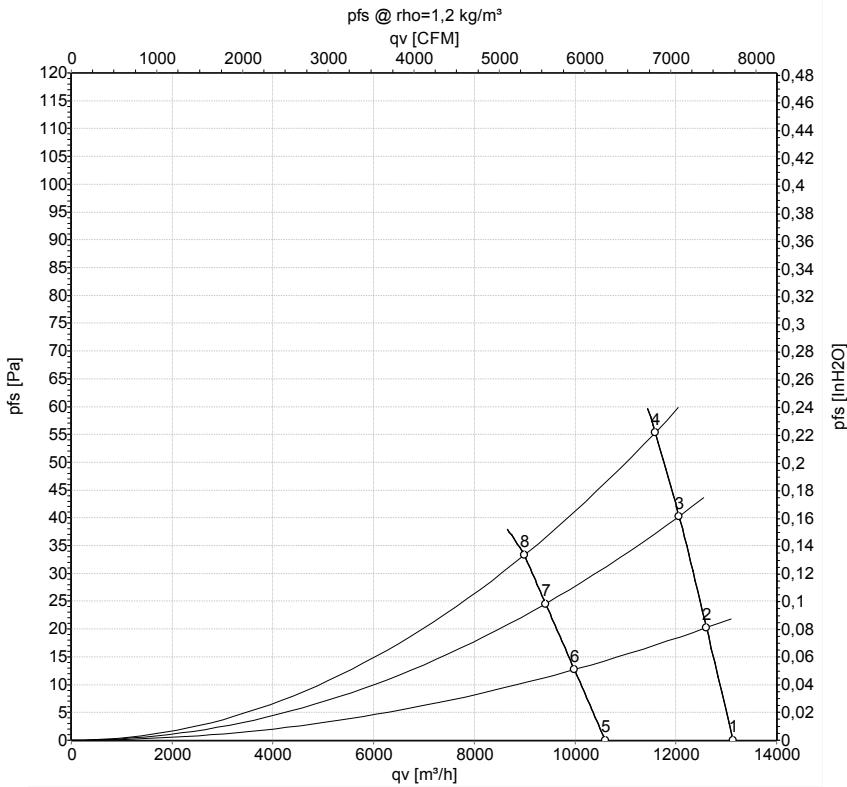

Measurement: LU-106032-1  
Measurement: LU-161590-1

Air performance measured according to ISO 5801 installation category A. For detailed information on the measurement setup, contact ebm-papst. Intake sound level: Sound power level according to ISO 13347 / sound pressure level measured at 1 m distance from fan axis. The values given are valid under the specified measuring conditions and may vary due to conditions of installation. For deviations from the standard configuration, the parameters have to be checked on the installed unit.

## Measured values

	Wired	U	f	n	P <sub>e</sub>	I	LpA <sub>in</sub>	LwA <sub>in</sub>	LwA <sub>out</sub>	qv	p <sub>fs</sub>	qv	p <sub>fs</sub>
		V	Hz	min <sup>-1</sup>	W	A	dB(A)	dB(A)	dB(A)	m <sup>3</sup> /h	Pa	CFM	inH2O
1	Δ	480	60	1095	698	1.23	73	80	80	13140	0	7735	0.00
2	Δ	480	60	1085	747	1.28	72	79	79	12610	20	7420	0.08
3	Δ	480	60	1080	782	1.32	72	78	79	12065	40	7100	0.16
4	Δ	480	60	1070	830	1.37	72	78	79	11590	55	6825	0.22
5	Y	480	60	870	497	0.74	68	75	75	10600	0	6240	0.00
6	Y	480	60	850	513	0.77	67	74	74	9985	13	5880	0.05
7	Y	480	60	835	528	0.80	67	73	73	9415	25	5540	0.10
8	Y	480	60	830	550	0.83	66	73	73	8995	33	5295	0.13

Wired = Wiring · U = Power supply · f = Frequency · n = Speed (rpm) · P<sub>e</sub> = Power consumption · I = Current draw · LpA<sub>in</sub> = Sound pressure level intake side · LwA<sub>in</sub> = Sound power level intake side  
LwA<sub>out</sub> = Sound power level outlet side · qv = Air flow · p<sub>fs</sub> = Pressure increase

